

Double-Link Beam Load Cell

FEATURES

- Capacities: 50k to 100k lbs.
- Nickel-plated element
- Certified to OIML R60 3000d and NTEP class IIIIL 10000 divisions
- Sealing: IP67 (DIN 40.050)
- Low profile, self-checking, and self-centering
- Optimized design specially for weigh-bridge use
- **Optional**
 - Conduit adapter
 - FM approved for use in potentially explosive atmospheres



APPLICATIONS

- Truck scales
- Railroad track scales
- “Legal-for-Trade” tank, bin and hopper weighing

DESCRIPTION

The 5223 is a hermetically sealed, end loaded, center supported double-ended shear beam.

This product is suitable for a wide range of truck and rail scales. It is designed to use parallel link

loading, considered by many weighing experts to be advantageous when compared to other loading techniques.

Fully welded stainless steel seals ensure high environmental integrity and provided that additional cable sealing is used, occasional submersion can occur without damage.

These products meet the stringent Weights and Measures requirements throughout Europe.

OUTLINE DIMENSIONS in millimeters

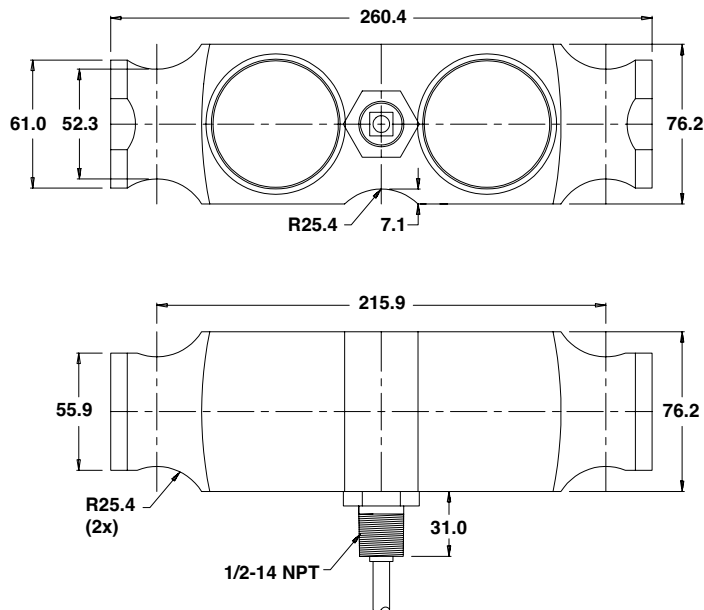

Cable specifications:

Cable length: 12m

+ Excitation	Red
- Excitation	Black
+ Output	Green
- Output	White
Shield	Transparent

Cable screen is not connected to load cell body. Performance may be affected if load cell cables are shortened.

Double-Link Beam Load Cell

SPECIFICATIONS				
PARAMETER	VALUE			UNIT
Standard capacities (E_{max})	50k, 65k, 100k			lbs.
Accuracy class according to OIML R-60 / NTEP	NTEP IIIIL	Non-Approved	C3	
Max. no. of verification intervals (n_{IC})	10000		3000	
Min. verification interval (V_{min})			$E_{max}/10000$	
Rated output (=S)	3			mV/V
Rated output tolerance	0.003			±mV/V
Zero balance	1.0			±% FSO
Combined error	0.0200	0.0300	0.0200	±% FSO
Non-repeatability	0.0100	0.0100	0.0100	±% FSO
Minimum dead load output return	0.0250	0.0300	0.0167	±% applied load
Creep error (30 minutes)		0.0300	0.0245	±% applied load
Creep error (20 minutes)	0.0027	0.0045		±% applied load
Temp. effect on min. dead load output	(0.0008)	0.0140	0.0070	±% FSO/5°C (°F)
Temperature effect on sensitivity	(0.0010)	0.0070	0.0045	±% applied load/5°C (°F)
Minimum dead load	0			% E_{max}
Maximum safe over load	150			% E_{max}
Ultimate over load	300			% E_{max}
Maximum safe side load	100			% E_{max}
Deflection at E_{max}	0.5 / 0.6 / 0.9			mm
Excitation voltage	5 to 18			V
Maximum excitation voltage	20			V
Input resistance	700±7			Ω
Output resistance	700±7			Ω
Insulation resistance	≥5000			MΩ
Compensated temperature range	-10 to +40			°C
Operating temperature range	-40 to +80			°C
Storage temperature range	-40 to +90			°C
Element material (DIN)	Nickel-plated alloy steel			
Sealing (DIN 40.050 / EN60.529)	IP67			

FSO—Full Scale Output

All specifications subject to change without notice.